

State Skill Competitions

Test project: Sample

Electronics

Skill-Electronics

Test project- Level 2

Skill Explained

The electronics industry is very diverse and has evolved into several special domains. Almost every aspect of today's world relies on, or directly uses, electronics technology.

Engineering Technicians/Technologists will work across many aspects of electronics, with increasing specialization and technical developments. The key areas of specialization, which can be seen as careers in their own right include the designing of prototype circuits, schematic capture and layout to create/verify/simulate schematic circuits and printed circuit boards. This is a specialized occupation in its own right, and also involves the creation of production documents such as Bill of Materials, Gerber Files and drill files. Electronics specialists work in a wide range of industries supported by highly technical specialist equipment. These tools are often specialized, and also include measurement test equipment. Computers and specialist software development tools are used to create programs for embedded systems and programmable devices. Embedded System design involves interfacing Microcontroller unit (MCUs) to the outside world via sensors/communication interfaces.

Eligibility Criteria- Competitors born on or after 01 Jan 1997 are only eligible to attend the Competition

Duration of Test project: 4 hours for State level

Preface

Section A-Test Project

Task A – Schematic Design

Task B – Design of Printed Circuit Board

Task C – Embedded System Programming

Section B-Marking Scheme

Section C-Infrastructure List (Tool and equipment including raw material)

Section D- Health, Safety and Environment

Section A

Task A – Schematic Design

Competitor Instruction Sheet

You have **60 Minutes** to complete this task

You are to complete designs, keep in the mind the following observations

1. Please complete the design according to the following requirements.
2. Use only the component from the part list of your designs.
3. You may not need all components in the parts list.
4. You can start using PCB design only after submitting the paper schematic.

Competitors can read component data sheet that is provided with only personal computer which contains data sheet pack. The hard copies brought by competitor can't be used, but competitors can read the hard copies provided with competition organizer. When you have completed your designs you are to submit your answers on the provided Answer Sheets to the Expert. You will then be given the schematic solution for schematic entry into PCB design software. You cannot start your PCB design in this phase of the Test Project.

Task B – Design of Printed Circuit Board

Competitor Instruction Sheet

You have **90 Minutes** to complete this task

1. Design printed circuit board using PCB design software tool.
2. Prepare the PCB design as per specified position of components in shown figure.
3. Complete the design, save PCB Gerber files in the pen drive.
4. Create a BOM, containing all information for your schematic design.
5. Create a pdf files as requested in the statement.
6. Follow the rules as specified in the statement.

Example of Test Project-Hardware Design

“Digital Industrial Counter”

Introduction

The task is to develop digital industrial counter, which is used to count input pulses/ events sensed by an U-shape opto-coupler

Here the counter is taking input /signal sensing from opto-coupler and display the count on seven segment displays. Initially the count on displays will be 00. At every event on opto-coupler count will increase by 1 and it will go till 20(twenty). Once it reaches to 20, a buzzer will beep. If further event comes at opto-coupler count will reset back to 00.

And this process keeps going on while POWER is ON.

Eg: 00 → 01 → 02 → 20 → 00 → 01.....

Block Diagram

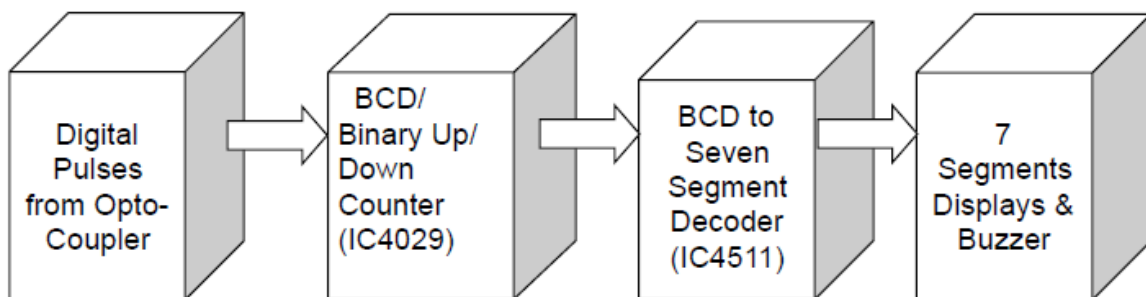

Figure1. Block Diagram

PCB Design

Submit the following PCB Gerber files to the experts in the usb sticks.

- *.GBL Bottom Layer
- *.GKO Keep Out Layer (Dimension)
- *.txt NC Drill File

Submit the following files as *.pdf Data

All schematics

PCB Top Layer (scale 1:1)

PCB Bottom Layer (scale 1:1)

Component Placement Side (scale 1:1)

PCB size is 180mm x 80mm and should be Single side PCB.

Place Power supply, 7-Segment units and controlling part as shown in the “Figure”.

Place wherever competitor wants to be electronically stable except assigned Component

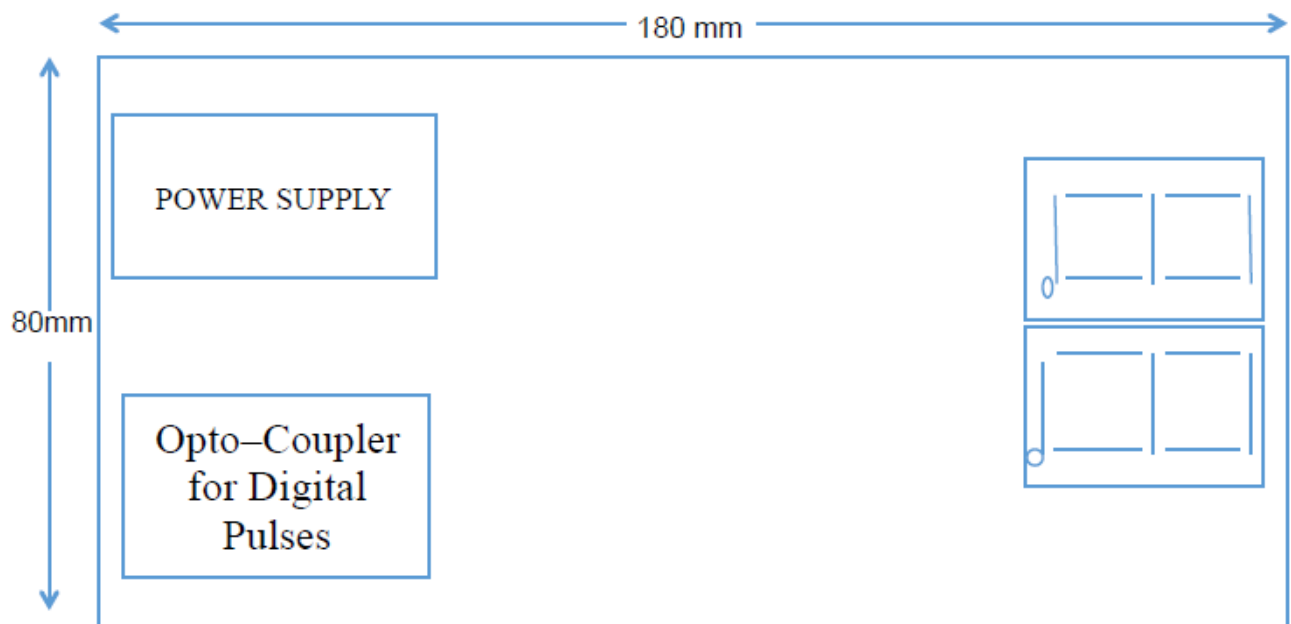

Figure2. PCB layout

The participant must design the circuit using the component given below:

Item	Parts name	Parts value (Model)	Qty.	Remarks
1	IC-Timer	NE555	4	
2	IC-Counter	4029	1	
3	Seven Segment Displays	14.2 mm (0.56 inch)	2	
4	Diode	1N4001 / 1N4007	4	
5	IC-Voltage regulator	LM7805	1	
6	LED 5mm	Red	1	
7	DC socket	12v	1	
8	Resistor	330 Ω , 1/4W, 5%	16	
9	Resistor	1K Ω , 1/4W, 5%	6	
10	Resistor	10K Ω , 1/4W, 5%	4	
11	Resistor	220K Ω , 1/4W, 5%	5	
12	U Shape Opto Coupler	Opto Coupler	1	
13	BDC to 7 Segment Decoder IC	IC4511	2	
14	Capacitor for Electric	100uF	1	
15	Capacitor for Electric	010uF	1	

16	Buzzer	Piezo-Buzzer	1	
17	Ceramic Capacitor	0.1u F	1	
18	Capacitor for Electric	220u F/16V	1	
19	AND Gate IC	IC74HC08	1	
20	Transistor	BC548	3	

Task C – Embedded System Programming

Competitor Instruction Sheet

You have **90 Minutes** to complete this task.

1. Write a program in embedded C language for a microcontroller.
2. Interface the required hardware modules like LCD, Motor, Keypad, Touch Screen etc. to demonstrate the required functionality.

Example of Test Project - Embedded System Programming

“Digital Electronic Safe”

Introduction

Digital Electronic Safe is used to keep highly valuable items at home and offices. It has a small storage space, which can be accessed by opening of an automatic door controlled by programmed microcontroller and circuits. The features of Digital Electronics Safe are:

1. 4-bit Secure Password
2. Owner can change Password
3. Notification for right and wrong password

Block Diagram

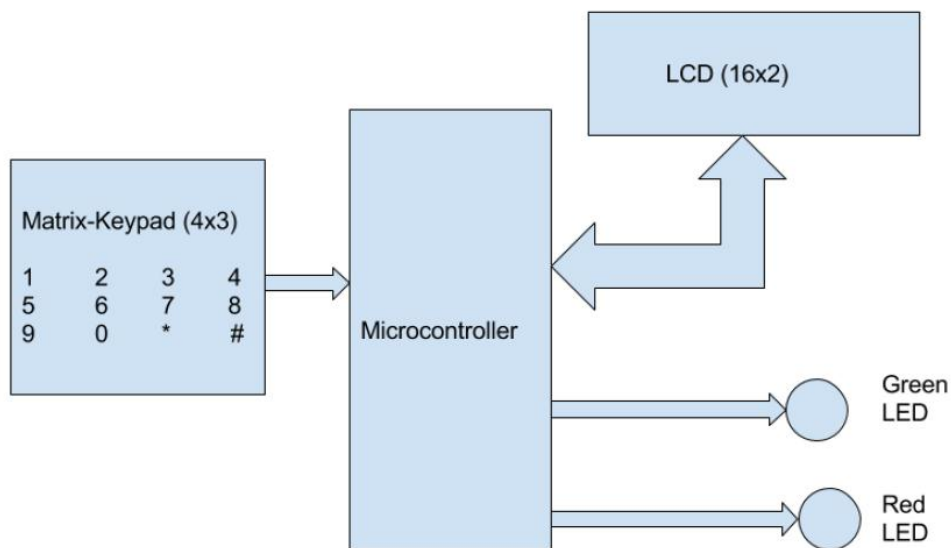

TASKS FOR THE COMPETITOR

The task is to write a program in embedded c language for microcontroller, used in digital electronic safe device to achieve following functions:

Sub Task A. Power on Display

When the device get switch on, it will display “Digital Electronics Safe” in first line and “IndiaSkills2018” in second line of 16x2 LCD.

Sub Task B. Default Password

There are 12 switches available as shown in block diagram to enter password.

Whenever user press any key after power on display, the second line of LCD should display “xxxx” and first line should display “Digital Electronics Safe” only.

The default password of device should be set as “1234”

Sub Task C. Password Check

When user enter password, either it will be right or wrong.

- If it is correct then display on second line should show “OPEN” and green LED should be on for 5 sec.
- If it is incorrect then display on second line should show “Wrong PWD” and red LED should be on for 5 sec.

Sub Task D. Password Change

The user has choice to change the password and it can be changed by following procedure:

User need to press * switch for 2 sec and thereafter second line of LCD should display

“New Password ----”

Thereafter user can enter any password of his choice and press # for 2 sec to store the password in RAM and come back to power on display screen.

Section B

Marking Scheme: The Assessment is done by awarding points by adopting two methods, Measurement and Judgments

- Measurement –One which is measurable
- Judgments-Based on Industry expectations
- Aspects are criteria’s which are judged for assessment
- In Electronics skill all markings are done on measurement basis. Marks awarded will be 0 or full marks.

a. Marking Scheme module wise with detailed assessment criteria

(a) Task - A: Development of circuit(s) - 20 marks

(a) Task - B: Design of PCB-board layout and production of Gerber files - 40 marks

(b) Task - C: Embedded System Programming -40 marks

b. Marking Scheme with detailed assessment criteria

Sub Criteria ID	Sub - Criteria Name or Description	Time	Aspect ID	Aspect - Description	Max Mark	Obtained Marks
Task A	Hardware Module-Schematic	1 hr.				

	Design (20 Marks)					
			1.1	Connection of R4	1.00	
			1.2	Connection of R20	1.00	
			1.3	Connection of R6	1.00	
			1.4	Connections of U13 IC	2.00	
			1.5	Connections of U10 IC	2.00	
			1.6	Connections of U14 IC	2.00	
			1.7	Connections of U11 IC	2.00	
			1.8	Connections of 7-segment 1	2.00	
			1.9	Connections of 7-segment 2	2.00	
			1.10	Connection of R21	1.00	
			1.11	Connection of Transistor Q2	2.00	
			1.12	Connection of pin3 of 555 IC U1	1.00	

			1.13	VCC and GND connection	1.00	
Task B	Hardware Module - PCB Design	1.30 hrs.	2.1	PCB Design Quality: Difference in the track widths	3	
			2.2	PCB Design Quality: Jumper Wires	3	
			2.3	PCB file generation & pdf files	3	
			2.4	PCB layout and Component Positioning- (Power supply block)	4	
			2.5	PCB layout and Component Positioning- (555 Timer Block)	4	
			2.6	PCB layout and Component Positioning- (Counter Block)	4	
			2.7	PCB layout and Component Positioning- (7-Segment LEDs Block)	4	
			2.8	PCB layout and Component Positioning- (Other Components)	4	
			2.9	PCB routing as per IPC standards	4	
			2.10	Over all design as per IPC standards	3	

			2.11	PCB Design Size	4	
Task C	Embedded System Programming (40 Marks)	1.30 hrs.	3.1	Display Digital Electronic safe (First Line)	4	
			3.2	Display India Skills 2016 (Second Line)	4	
			3.3	Any key press Password ****	4	
			3.4	Any key press Default password- 1234	4	
			3.5	On correct password Display- OPEN	4	
			3.6	On correct password Green LED ON	4	
			3.7	On incorrect password Red LED ON	4	
			3.8	Change password Password mode- press * for 2 sec	4	
			3.9	Change password Password mode- press * for 2 sec New password - - - -	4	
			3.10	Change password Save password (RAM store) press # for 2 sec	4	

Total

100

Section C

Infrastructure List (Tool and equipment including raw material)

The quantity is given for each candidate

S. No.	Item	Requirements/Specification	Qty
1	Workbench	2'x3'	2
2	Soldering iron	15 W	1
3	Soldering iron stand	Metal	1
4	Solder wire	0.6/0.7/0.8mm	100gm
5	Magnifying glass	Hand/table mounted	1
6	Calculator	Scientific	1
7	Desktop/Laptop	13,4gb,500gb HDD or higher	1
8	Printer	Deskjet/LaserJet	1
9	Electronics components	As per specified in the task	1
10	Multimeter	Digital 3 ½ digit	1
11	Software	PCB design (Eagle/Proteus/Altium)	1
12	Paper	A4 Size	2
13	Pen/Pencil/Eraser	Blue/HB	1
14	Power Supply	Digital Power supply 3-15V/5A	1
15	Power Socket	AC socket	3
16	ESD Mat	2'x3'	2
16	ESD point	Grounding point	2
17	Microcontroller Development Kit	Any MCU with which the contestant is comfortable with like Arduino / 8051 / ARM	1
18	Matrix Keypad	3 x 3	1
19	LCD	16 x 2 LCD	1
20	LEDs	Red LED, Green LED	2
21	Berg Connectors	Male-Male Female-Female Male-Female	10 10 10

Section D

All individuals must have Electrostatic Discharge (ESD) awareness and use ESD straps when working with components/circuits.

All individuals must wear eye protection while soldering or cutting components.

It is recommended that shoes have closed toes and be ESD safe.

