



Skill India
कौशल भारत - कुशल भारत



India**skills**



N · S · D · C
National
Skill Development
Corporation

Transforming the skill landscape

Sample Test Project

District / Zonal Skill Competitions

Skill- Joinery

Category: Construction and Building Technology

Table of Contents

A. Preface	3
B. Test Project.....	4
C. Marking Scheme.....	6
D. Infrastructure List.....	8
E. Instructions for candidates	9
F. Health, Safety, and Environment	10

Section - A

A. Preface

Skill Explained:

Joinery is a part of woodworking that involves joining together pieces of timber or lumber, with one another by using only wooden elements. The characteristics of wooden joints - strength, flexibility, toughness, appearance, etc. are derived from the properties of the materials involved and the purpose of the joint. Therefore, different joinery techniques are used to meet differing requirements. For example, the joinery used to construct a house can be different from that used to make puzzle toys, although some concepts overlap.

Eligibility Criteria (for IndiaSkills 2018 and WorldSkills 2019):

Competitors born on or after 01 Jan 1997 are eligible to attend the Competition.

Total Duration: 3 Hrs

Section - B

B. Test Project

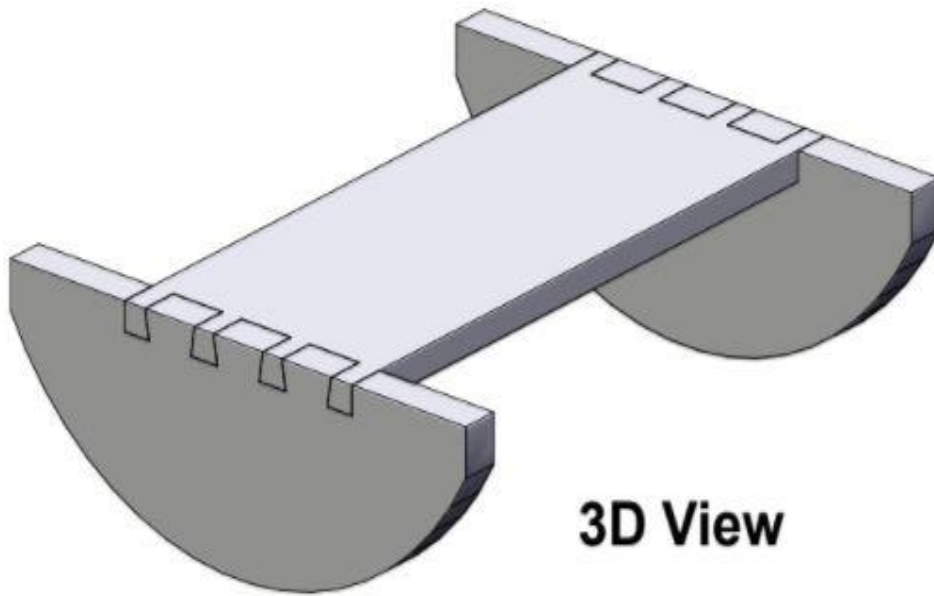

3D View

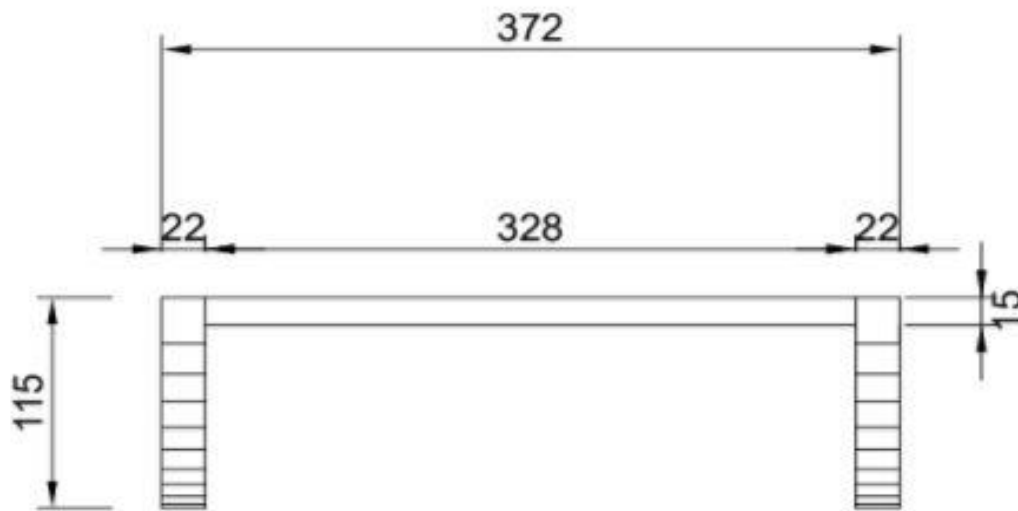

Front Elevation

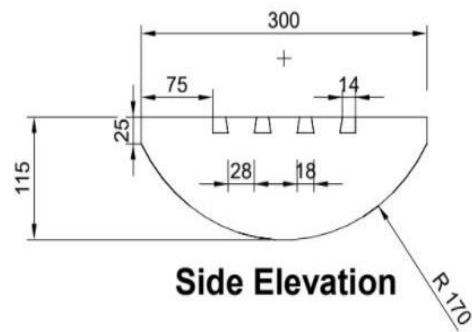
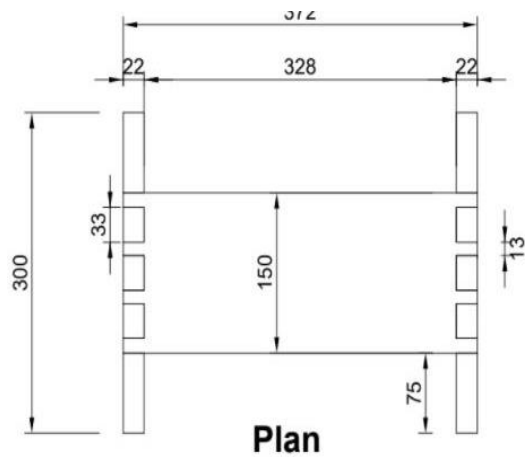

Instructions for Competitors

Working Instructions

- After face marking and setting out of the case competitors must bring them to the experts for marking.
- Before gluing, must present the frames to the experts for marking
- Hand tools can be utilized for finishing your work.
- The competitors must keep track of the time by themselves.
- The change in timing or additional time will be decided by the by experts, only in cases of illness and accidents.
- The maximum working time is 3 hrs.

Section – C

C. Marking Scheme

The Assessment is done by awarding points by adopting two methods, Measurement and Judgments

- Measurement – One which is measurable
- Judgments - Based on Industry expectations

Measurement is used to assess accuracy, precision, and other performance which can be measured in unambiguous way. Mark is awarded in full for a dimension within tolerance and zero when it is out of tolerance.

Judgment is used to assess the quality of performance, about which there may be small differences of opinion.

The scores from 0 to 3 are awarded for conformity with industry standards (score 1 stands for 1/3 and score 2 for 2/3 of the maximum mark allotted for the criterion).

- 0: performance below industry standard to any extent, including a non-attempt
- 1: performance meets industry standard
- 2: performance meets industry standard and surpasses that standard to some extent
- 3: excellent or outstanding performance relative to industry's expectations

Example-Judgment Marking

If maximum marks for Judgment criteria is 1 and if all 3 Experts (Juries) give 3 points to a candidate, the candidate will get 1 mark for that aspect. If 2 Experts give 3 and 1 Expert gives 2 points, then candidate will get $(2+2+1/9) * 1 = 0.55$ marks for that aspect (out of 1).

Aspects are criteria's which are judged for assessment

Marking

Main criteria	Judgment	Measurement	Total
Main dimensions		30	
Conforming od Drawing and joints	50	10	
Assembly			
Surface finish and material	10		
Grand Total	60	40	100

Marking scheme

1. Overall height should be 115 mm	20
2. Overall width should be 372mm	10
3. Overall depth should be 300mm	10
4. Measurements of joint as per drawing	10
5. Curved design on sides	10
6. Face marking	05
7. Joints before gluing	15
8. Joints after gluing	15
9. Sanding	05

Total = 100

Section - D

D. Infrastructure List

- Workshop Installation-Tools & Equipment positioned by Organizers
- Tool Kit-Tool & Equipment allowed to be brought by competitors for competitions
- All equipment and material will be provisioned by the Organizers at site including raw material; White oak wood

Infrastructure list

1. Firmer chisel set
2. Mortise chisel set
3. Dovetail saw
4. Coping saw
5. Measuring tape
6. Mallet
7. Geometry instruments
8. Bevel square
9. Smoothing planer
10. Try square
11. Mortise gauge
12. Zig saw machine

Material list

- | | | | |
|----------|------------|-------|----------------|
| 1. Top | 372x150x15 | 1nos. | White oak wood |
| 2. Sides | 300x115x22 | 2nos. | White oak wood |

Section – E

E. Instructions for candidates

For Construction of the task;

- After face marking and setting out of the case competitors must bring them to the experts for marking.
- Before gluing, must present the frames to the experts for making.
- The surface should be fit for the polishing.
- The competitors must keep track of the time by themselves.
- The timing will be stop by experts, only in cases of illness and accidents.
- Your own measuring equipment rulers etc. Can be available after finishing your test for controlling of the measurements.

Section – F

F. Health, Safety, and Environment

1. All accredited participants, and supporting volunteers will abide by rules and regulations with regards to Health, Safety, and Environment of the Competition venue.
2. All participants, technicians and supporting staff will wear the required protective Personnel clothing. The Competitors must wear proper dress suiting the task and wear goggles while performing wood work
3. All participants will assume liability for all risks of injury and damage to property, loss of property, which might be associated with or result from participation in the event. The organizers will not be liable for any damage, however in case of Injury the competitor will immediately inform the immediate organizer for medical attention.